

# METHOD STATEMENT FOR INSTALLATION OF WIRING DEVICES & ACCESSORIES

## RED LINE NORTH ELEVATED AND AT GRADE

### Revision and Issue Records

Review History

Document No.	Revision	Title
M002-RLR-ELE-MES-00010	1	MS for Installation of Wiring Devices & Accessories

1	6/12/2016	For SONO	SHA	MAG	PSE
<b>Rev. No</b>	<b>Date</b>	<b>Description</b>	<b>Prepared</b>	<b>Reviewed</b>	<b>Approved</b>

Document Review and Approval

Signed : _____ P.Serra	Signed : _____ M.Agrimakis	Signed : _____ M. Ali	Signed : _____ R.Neri
<input checked="" type="checkbox"/> <b>Originator</b>	<input checked="" type="checkbox"/> <b>Construction</b>	<input type="checkbox"/> <b>Stakeholder</b>	<input checked="" type="checkbox"/> <b>Quality</b>
Signed : _____ J. Brink	Signed : _____ E. Ndarake	Signed : _____ M. Thompson	Signed : _____ D. Bernasconi
<input checked="" type="checkbox"/> <b>Health and Safety</b>	<input checked="" type="checkbox"/> <b>Environment</b>	<input type="checkbox"/> <b>Commercial</b>	<input checked="" type="checkbox"/> <b>Cont. Rep.</b>

Document Control

Controlled Copy Issue Log:

This document control list is only applicable for hard copies that may be required outside EDMS.  
The hard copy document has been assigned as below and will be reissued automatically upon any future revision

Copy	Company Name	Representative	Date

**Contents**

**1 Definitions and Abbreviations: ..... 3**

**2 Purpose: ..... 4**

**3 Scope of Method Statement: ..... 4**

**4 Work Execution: ..... 4**

**4.1 General Supplied Items: ..... 4**

**4.1.1 Personnel: ..... 4**

Document No.	Revision	Title
M002-RLR-ELE-MES-00010	1	MS for Installation of Wiring Devices & Accessories

4.1.2	Equipment and tools :	6
4.1.3	Material	7
4.1.4	Handling and Storing of Materials	7
4.2	Site Execution	8
4.2.1	Program	8
4.2.2	Pre-Requisites	8
4.2.3	Pre-Installation Information	9
4.2.4	Site Access	10
4.2.5	Installation Procedures	10
4.2.6	Installation Requirements	10
4.2.7	Fixing Methods Not to Be Practiced	12
4.2.8	Installation Procedure	12
4.2.9	Area Classification and Types of Wiring Devices	13
4.2.10	Installation of Lighting Switches	18
4.2.11	Installation of Ceiling Rose (Plug Type)	20
4.2.12	Circuit Continuity: Test	22
4.2.13	IDENTIFICATION OF ELECTRICAL SERVICES	23
4.2.14	REDLINE MARK-UP & AS-BUILT	24
5	Quality	24
5.1	Quality Records:	24
6	Health and Safety Plan:	24
6.1	Specific Measures:	25
7	Environmental:	27
8	Interfaces and Permits	27
8.1	Interfaces	27
8.2	Permits	27
9	Appendices / References:	27
9.1	Appendices:	27
9.2	References:	27

## 1 Definitions and Abbreviations:

---

Table 1: Definitions and Abbreviations

Abbreviation	Definition
BS	British Standard
HS	Health, and Safety
ITP	Inspection and Test Plan
MSDS	Material Safety Data Sheet
PMC	Project Management Consultant
QA/QC	Quality Assurance / Quality Control

Document No.	Revision	Title
M002-RLR-ELE-MES-00010	1	MS for Installation of Wiring Devices & Accessories

Abbreviation	Definition
QCS	Qatar Construction Specification
SONO	Statement of No Objection
PPE	Personal Protective Equipment
RLN-EAG	Red Line North Elevated and At Grade
RLR JV	Rizzani de Eccher, Lotte and Redco - Joint Venture
DB	Distribution Board
MCB	Motorized Circuit Breaker
SMDB	Sub Main Distribution board
MDB	Main Distribution Board
ITP	Inspection Test Plan
FAT	Factory Acceptance Test
MS	Method Statement
QR	Qatar Rail
QCS-2014	Qatar Construction Specification

## 2 Purpose:

The purpose of the method statement is to describe the procedure for material delivery inspection, installation and inspection of the Wiring Devices & Accessories at Stations. The Intent of this report is to explain, the methods to be adopted to ensure works conducted on site are in compliance with approved design & material approvals as per Project specifications.

## 3 Scope of Method Statement:

The scope of application of this method statement is the Installation and inspection of Wiring Devices & Accessories for RedLine North Elevated & At Grade. (Chainage: 25+285 to Chainage: 31+950, Section of the RLN-EAG Project.

## 4 Work Execution:

### 4.1 General Supplied Items:

#### 4.1.1 Personnel:

Ref.	Trade & Despines	Responsibility

Document No.	Revision	Title
M002-RLR-ELE-MES-00010	1	MS for Installation of Wiring Devices & Accessories

1	MEP Construction Manager	<ul style="list-style-type: none"> <li>Delivering the overall works in a safe and timely manner, ensuring conformance with the approved design.</li> <li>Leading the team of engineers and surveyors, guiding them in the delivery of the works.</li> <li>Verifying that work done is in accordance with requirements of contract.</li> <li>Ensuring the quality standards set for the work are achieved and the work team adhere to the QA/QC and HS requirements of the contract.</li> </ul>
2	Systems Assurance Engineer	<ul style="list-style-type: none"> <li>Establish the system assurance process.</li> <li>Manage the RAMS team and EMC team in delivering the system assurance submissions.</li> </ul> <p>Liaise with the System Assurance Manager for all safety and RAM related activities respectively.</p>
3	Project/Site Engineer	<ul style="list-style-type: none"> <li>Ensuring that the works are being carried out in accordance with contract requirements and this Method Statement.</li> <li>Management onsite to ensure that the team carries out the works in time with the delivery schedule.</li> <li>Implementation of and adherence of the team to the QA/QC and H&amp;S policies and procedure.</li> </ul>
3	QA/QC Manager	<ul style="list-style-type: none"> <li>The preparation of the company's QA manual control and supervision of all amendments and revisions</li> <li>Monitor all quality related activities on the project</li> <li>Perform all internal and external audits on behalf of the company's management</li> <li>Preparation, monitoring, training of project staff on method statements, and control of material on site.</li> </ul>
4	QA/QC Engineer	<ul style="list-style-type: none"> <li>The QA/QC Engineer is the overall responsible for the implementations of this procedure and will carry out the material inspection to ensure that materials received on site are approved materials.</li> <li>He will be conducting surveillance and inspection duties at various stages of the project delivery to ensure compliance to contract requirements and to QA / QC requirements.</li> <li>He will monitor the installation works according to the approved drawing &amp; method statement.</li> <li>He will coordinate with the Supervisory Consultant to carry out inspection/testing of the completed works.</li> <li>The QA/QC Engineer is responsible for the detail application of this procedure for the inspection and testing, to coordinate with the Construction Manager and Site Engineer for the inspection of on-going work.</li> </ul>

Document No.	Revision	Title
M002-RLR-ELE-MES-00010	1	MS for Installation of Wiring Devices & Accessories

5	Surveyor	<ul style="list-style-type: none"> <li>• Setting out all planned works.</li> <li>• Monitoring the works being carried out to ensure they are at the correct levels and measurements.</li> <li>• Maintaining documents relevant to alignment and height control.</li> </ul>
6	Document Controller	<ul style="list-style-type: none"> <li>• Documenting, distributing and maintaining data in the prescribed format.</li> <li>• Making the necessary data available as requested by the team or the client.</li> </ul>
7	HS Inspector	<ul style="list-style-type: none"> <li>• <b>Identify</b> HS requirements, non-compliance or otherwise by conducting both formal and informal audits and communicate said to relevant site management</li> <li>• <b>Advise</b> site management on HS substandard acts and HS substandard conditions on a continuous basis and record said.</li> <li>• <b>Coordinate</b> and record action by site management as identified and advised.</li> <li>• <b>Verify</b> actions taken by site management , record and report accordingly</li> <li>• <b>Conduct</b> relevant HS administrative functions and additional tasks as directed by HS Management.</li> </ul>
8	Supervision Engineer	<ul style="list-style-type: none"> <li>• Checking the compliance of works to the design.</li> <li>• Carrying out comprehensive supervision of all construction works.</li> <li>• Confirming that the work executed complies with the approved design and be responsible for checking the construction works.</li> </ul>

All of the above will individually be responsible for a safe and healthy operational environment consideration of all the workers in their team related to the execution of their duties and any other personnel. Furthermore one group of workers is planned for execution of installation of Wiring Devices & Accessories. This group will perform all activities. The group will have following labour profile.

#### Labours/Workers

No.	Description	No	Description
1	Electrical Supervisor	3	Electrician
2	Electrical Forman	4	Labours

#### 4.1.2 Equipment and tools :

The typical construction equipment requirements is as listed below, and will be used for Installation activities at site.

#### General Tools used for this activity

- PPE for all staff and labour
- Measuring tapes and setting out markers
- Electrician Tool Box with all tools
- Spirit Level
- Screwdriver set
- Maker/Whitener

Document No.	Revision	Title
M002-RLR-ELE-MES-00010	1	MS for Installation of Wiring Devices & Accessories

- Hand Lugs Punch
- Wiring Lugs and Heat Shrink Sleeve
- Identification Tags
- Insulation Tape
- Hammer
- Flat File
- Spanners Set
- Heat Gun
- Multimeter & Megger Tester with Valid Calibration Certificate
- Cutting Pliers
- Cleaning Clothes
- Barrier Warning Tape & Portable Emergency Lamp
- Mobile Scaffolding (if Required)
- Man Lift (if Required)
- Ladders (if Required)
- Drilling Machine

Note: All the powered tools shall be suitable for use of 220V - 240V power Supply.

The above tools and equipment shall be checked for operational suitability before each shift of commencement of works including, but not limited, to safety and operational compliance. The same shall be executed for all small tools and miscellaneous items.

Equipment may be substituted subject to availability and actual requirements on the day.

The type and quantities of equipment are subject to change to suit the site requirements and to meet the construction program.

#### 4.1.3 Material

All materials to be utilized for the Wiring Accessories & General Power Systems to be used at Stations (Platform area, Concourse area and under Platform area) and will be provided in accordance with Contract's specifications and subject to the Engineer's Approval.

- BS 1363 13 A plugs, socket-outlets, adaptors and connection units
- BS 3676 For Switches
- BS 5419 For fused connection units

Materials will be tested in accordance with Inspection and Test Plan.

1. Material shall be as per Project Specification and must be approved by the Engineer.
2. Approved material (Switch Sockets outlets & Isolators) shall be used for different areas of the Project as per approved shop drawing.
3. For all Wiring Accessories, it must be ensured that all fixtures comply with the KAHARMAA Rules.

For emergency power supply and wiring accessories types shall be according to Qatar Civil Defence requirements.

#### 4.1.4 Handling and Storing of Materials

On receipt of wiring accessories, the materials shall be handled & stored in line with the following procedure:

1. Delivered Material and its parts shall be completely identified in accordance with approved material and approved drawings prepared for this work.
2. Any discrepancies, damage, and etc. found to the materials will be notified and reported to QA/QC Engineer and Project Engineer for further action.
3. Materials found not suitable for site use should be removed from site immediately.  
While unloading, shifting and storage, it should be ensured that there are no damages.

Document No.	Revision	Title
M002-RLR-ELE-MES-00010	1	MS for Installation of Wiring Devices & Accessories

4. Do not put the cartons down on to hard ground with a bang.
5. Put the cartons down only on ground that is sufficiently hard to prevent the base timber sinking into it.
6. Leave sufficient space between individual cartons.
7. Store all wiring fittings cartons in upright position.
8. Store the identified material in accordance with the manufacturer's instructions, above ground, properly protected from the weather and construction activities.
9. The storage area shall be kept in proper level, so that the stacked wiring accessories may not get damaged.
10. Ensure that the issued materials are of approved specifications I submittals and as per the requirement of the area shop drawings. (I.e. Make, size, Model I Type etc.).
11. Where manual handling is to be utilized it is imperative that a proper load assessment is undertaken and correct manual handling techniques are used to avoid injury. Safety and careful handling should be top priorities when handling materials.
12. Store all fittings and loose shipped materials indoors in a dry (Water Free) area.



**Sample Figure - A (Wiring Accessories Storages)**

## 4.2 Site Execution

### 4.2.1 Program

Installation of Wiring devices is expected to be performed starting **MAY**-2017. Detail schedule of Installation activity will be provided in the weekly update of the 3-weeks look ahead construction schedule.

### 4.2.2 Pre-Requisites

1. To make sure that the entire installation is in conformance and in accordance with the design intent of the project for the Electrical and Low Voltage System in addition to the specification and as per approved shop drawings and comply with Local and International Standards.
2. Adhere to the drawings as closely as possible. The right is reserved to vary the type of wiring accessories if conflict with the local rules and height according to the site condition if any clash arises.
3. Before beginning installation in any area, examine all parts of the adjoining work onto which applicable work is to be placed. Should any condition be found which will prevent

Document No.	Revision	Title
M002-RLR-ELE-MES-00010	1	MS for Installation of Wiring Devices & Accessories

the proper execution of the work, installation shall not proceed in that area until such conditions are corrected by the contractor.

#### 4.2.3 Pre-Installation Information

##### Types of electrical circuits

They are ring circuits, radial circuits and lighting circuits.

1. Socket circuits used in GLU shall be Ring Circuits. A cable/wiring leaves the distribution board and travels to each socket to be connected and when it reaches the last socket it then returns to the distribution board, thus creating a ring. The advantage of this system is that power can reach the sockets in the circuit from both directions, which reduces the power load on the cable/wire. Figure- 1.

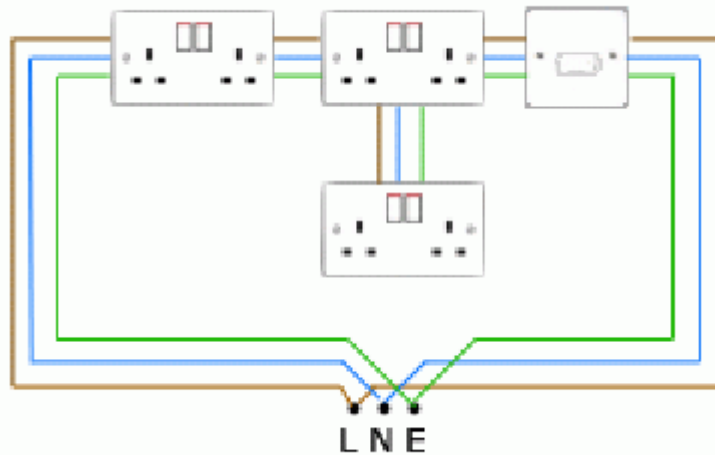

**Sample Figure- 1 (Ring Circuit for Power Sockets)**

2. Lighting circuits are basically Radial Circuits. There are two distinct types of lighting, circuit the loop-in circuit and the older junction box circuit.
  - a. The loop-in circuit has a cable, running from light to light terminating at the last light as in the conventional radial circuits and then single cable run from the lights to the light switches. Figure- 2.

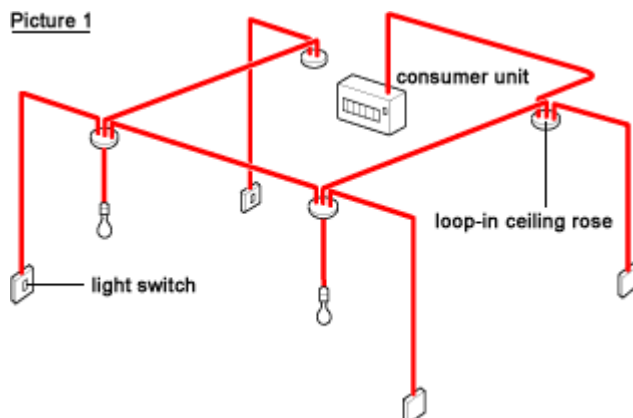

**Sample Figure- 2 (Loop in Circuit for Lights to be Used)**

- b. The other type of lighting circuit has a junction box for each light. The cable runs from the distribution board to the first junction box and then onto the next terminating at the last junction box. Then another cable is run from each junction box to its light and another wire from the junction box to that light switch. Figure- 3
  - c. Note junction box methodology shall not be used in this project

Document No.	Revision	Title
M002-RLR-ELE-MES-00010	1	MS for Installation of Wiring Devices & Accessories

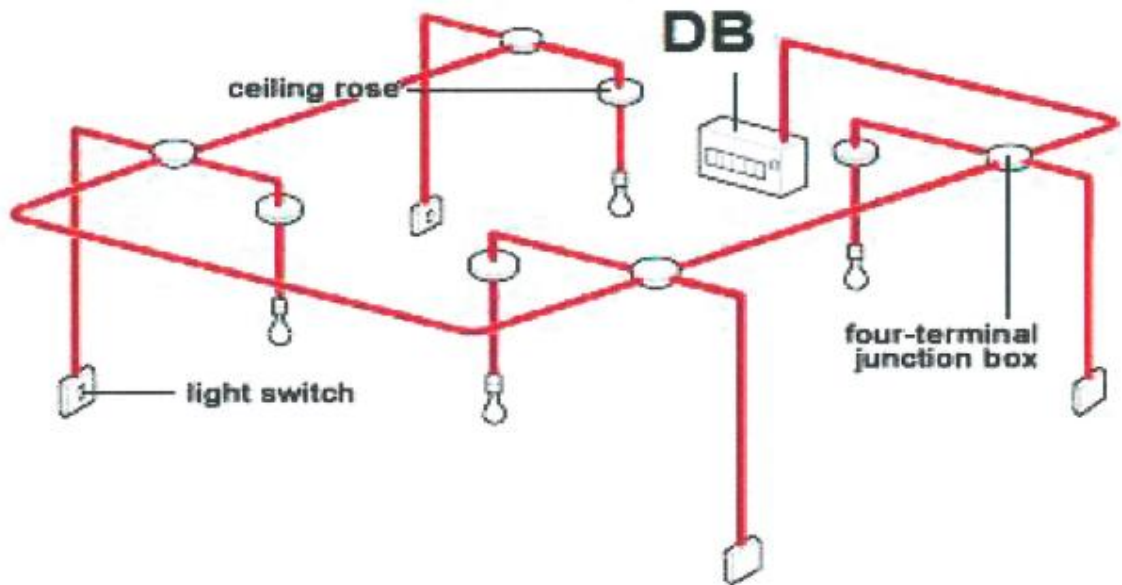

**Sample Figure- 3 (Junction Box Circuit for Lights)**

#### 4.2.4 Site Access

1. Clearly designated walkways must be established to allow persons to access the tunnel/site safely
2. Walkways must be maintained free from obstruction and any debris.
3. Adequate illumination must be provided for access routes and walkways.
4. Signs must be displayed to indicate the routes to be taken by persons, changes in routes must be clearly communicated.
5. All safety measures shall be taken care as per the instruction of HS Department.

#### 4.2.5 Installation Procedures

Before the commencement of installation, the following are required to be carries out.

1. All materials and documentation relevant to this particular section of works will be checked and verified ensuring that these are correct and approved type.
2. Prior to the commencement of works, ensure that the areas for permanent installation are ready, accessible and in suitable condition.
3. Check that the wiring accessories are new free from dirt, damage and corrosion
4. It should be verified that no combustible materials are used.
5. All installation Locations are as per approved shop drawing.
6. Benchmark Installation is approved
7. Installation of MEP utilities shall only commence when all associated civil works are completed.
8. Check all wiring works were completed and the wires were tested for insulation resistance and ensure that the test are verified and signed-off by the Consultant. Continuity Test shall be carried out before the installation of wiring and power feeding accessories.

#### 4.2.6 Installation Requirements

It has been presumed that all associated wiring works and testing has been completed and accepted by the Supervisor Engineer.

Document No.	Revision	Title
M002-RLR-ELE-MES-00010	1	MS for Installation of Wiring Devices & Accessories

Switched socket outlets, fused connection units, isolators and the like shall be installed to serve various fixed and portable equipment and general appliances with end to end connection termination.

1. Clear all boxes from cement stains and foreign materials.
2. Fix wiring accessories ensuring that they are fixed properly and squarely aligned .
3. Ensure that the type of wiring devices shall be as approved type as to the areas where they are going to fixed.
4. Ensure that all connections are correct and the wiring devices and boxes shall be earthed.

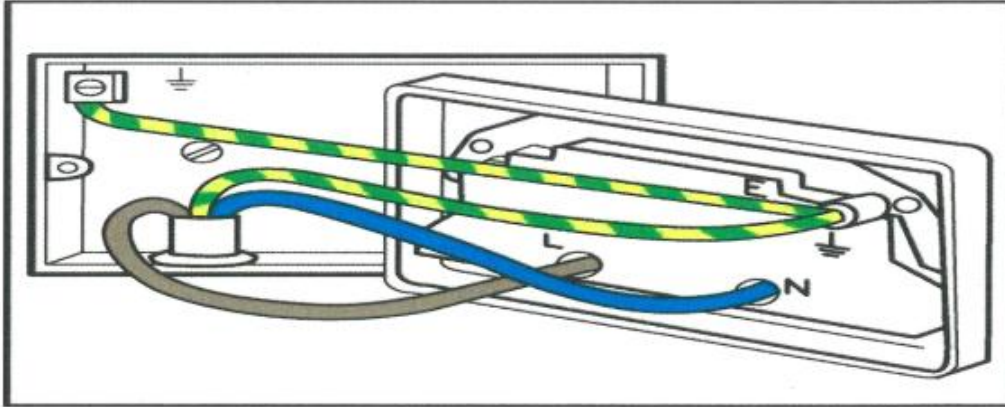

**Sample Figure - 4 (Back Box to be earthed)**

5. Cover all device plates with plastic sheet to protect the wiring accessories.
6. Ingress protected receptacles shall be provided in all areas exposed to dust and slashing water.
7. Equipment that requires fixed connection or heavy electric power outlets shall be supplied by means of flexible cord, from suitable disconnect switches mounted adjacent to the equipment.
8. Receptacles connected to the emergency power system/UPS system shall be properly colour coded/designated.
9. All special purpose receptacles/power outlets indicated for specific equipment shall be on a separate dedicated circuit.

*Mounting Heights of Electrical Accessories as per [the Models provided](#), (for reference see the [figure below](#))*

Document No.	Revision	Title
M002-RLR-ELE-MES-00010	1	MS for Installation of Wiring Devices & Accessories

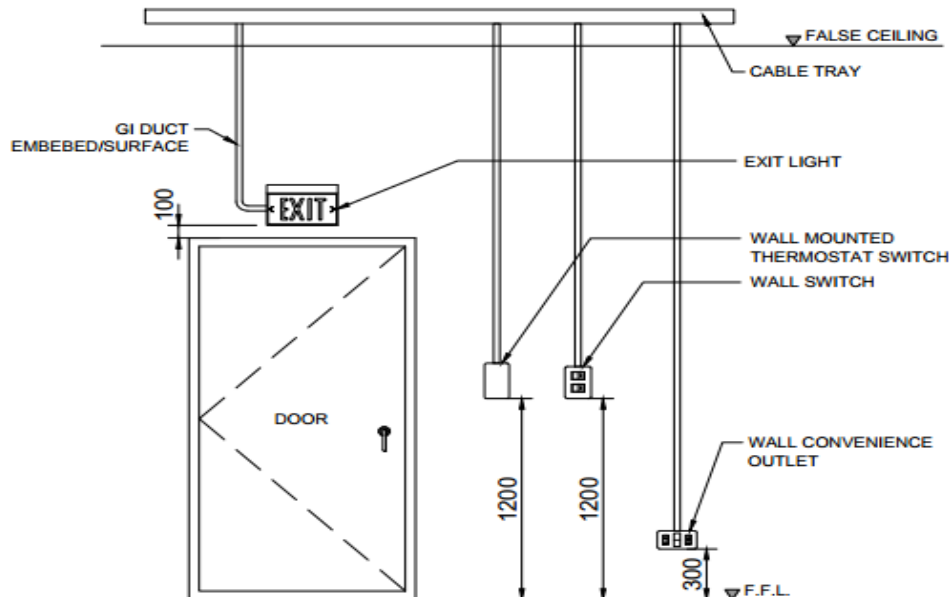

13
**TYPICAL MOUNTING HEIGHT  
DETAIL OF DEVICES**  
AA-26295 SCALE: NTS

**Sample Figure - 5 (Mounting Height Details)**

*As per Drawing M002-RLR-ELE-DWG-RNST080-26295*

#### 4.2.7 Fixing Methods Not to Be Practiced

Do not use the following fixing methods in any case:

1. Drilling structural steel work
2. Hanging supports with loose back plates under floor screed
3. Wooden or fibre wall plugs
4. Built-in fixings unless specifically detailed in the specification or on the drawings.

#### 4.2.8 Installation Procedure

The approved drawings for each area shall be reviewed and shall be released for installation as per the priority shown in the programme of works.

1. All works shall be undertaken in a neat and workmanlike manner to ensure quality installation.
2. Mounting heights of switches, sockets and all other sundry devices shall be as per approved drawings and KAHRAMAA standard.
3. Before commencing the work ensure the exact location of outlet boxes.
4. Externally mounted outlet boxes shall be totally sealed to ensure water tightness.
5. Lighting switches shall be installed at the strike side of the door, approximately 150mm from the edge of door frame.
6. Cover plates shall be installed with all four edges in continuous contact with finished wall with an alignment tolerance of 1.5mm.
7. All switch assembly louvered plates shall have their earthing terminal connected to the earth terminal attached to the switch box by an insulated 2.5mm<sup>2</sup> protective conductor.
8. Wherever two or more switches are grouped together and connected to the same phase, multi gang devices and common plate shall be used.
9. Waterproof switches shall be water tight 1P56 rating or as per project specification.

Document No.	Revision	Title
M002-RLR-ELE-MES-00010	1	MS for Installation of Wiring Devices & Accessories

10. Double pole switches shall be fitted with neon indication lamps and the rating shall be as per project specification.
11. Ceiling roses shall be of all insulated type provided with insulated terminals for the switched live, neutral, protective conductor and loop in facilities.
12. Ensure all the socket outlets shall be installed as per the phase indicated in the approved shop drawings.
13. Ensure all the outdoor socket outlets shall be weather proof made.
14. Shaver socket outlets shall be suitable for installation in bathrooms incorporate two pin shuttered outlet configuration and have terminals to accept 2.5mm<sup>2</sup> conductors.
15. Cooker control units shall be incorporated of approved rating, double pole switch.
16. Junction box, pull box and terminal boxes shall be fixed where indicated and where required to facilities pulling of wires and cables and connection of future appliances.
17. Boxes shall be fixed as invisible as possible, but shall be accessible after work completed.
18. Pull boxes shall be fixed maximum 10m spacing and to limit the number of bends in conduit to not more than two 90degree bends.
19. Disconnect switches, switch fuses; fused connection units, timer and time clocks shall be installed as per approved drawing and project specification.

#### 4.2.9 Area Classification and Types of Wiring Devices

The detail is mentioned below for wiring devices installation in different areas of the project in scope

##### a. Stations General

General Sockets: (staff accommodation and offices)

- 13 Amp, 3 pin, single gang and switched type and 240 Volt, 30mA RCD protected.
- LSOH cabled supply, see drawings from location and number of within the rooms.

##### b. Platform & Concourse Sockets

- 13 Amp, 3 pin, single gang and switched type and 240 Volt, 30mA RCD protected impact resistant type with hinged protective flap (IP56) water tight.
- Non-essential LSOH cabled supply.

##### c. Circulation Areas

Small power socket outlets will be provided for general use and for cleaning machines etc. throughout station areas. Power outlets for specific connection and use of apparatus shall be provided according to approved drawings. General station power outlets will be nonessential supplies.

Installation of twin/single, 13 amp switched socket outlets shall be spaced at not less than 10m centres. Mount height shall be according to local rules or otherwise advised by the Engineer.

In toilet areas, wiring devices shall be provided according to approved shop drawing to fixe equipment such as,

- i. Water heaters
- ii. Hand dryers
- iii. Urinal control valves

In the concourse areas, wiring devices shall be provided according to approved shop drawing to fixe equipment such as,

- i. Ticket fare machines
- ii. Vending machines

Document No.	Revision	Title
M002-RLR-ELE-MES-00010	1	MS for Installation of Wiring Devices & Accessories

iii. Turnstiles and barriers

#### d. Installation Devices

##### i. Installation of Power Socket (13 Amp, 3 Pin)

1. There are two types sockets Single and Double Switched Socket Outlet.
2. Connect the cables as shown in the wiring diagram. The diagram shows connections for a ring main circuit. Figure — 6
3. For radial circuits or a spur off a ring main there will only be one cable.

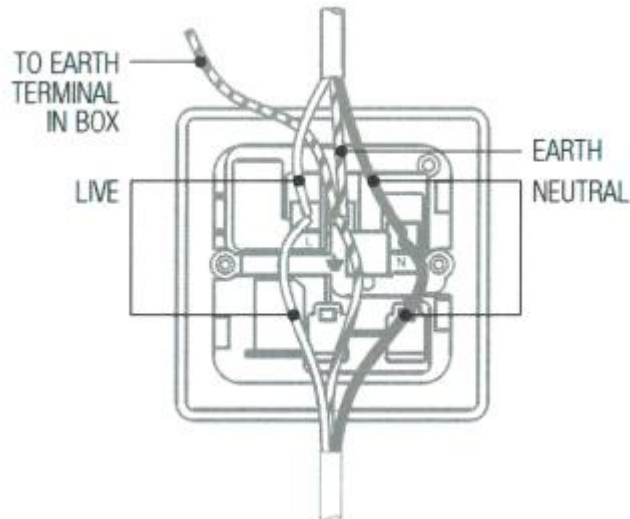

**Sample Figure — 6 (Signal Switch Socket Outlet Connections)**

4. Connect the cables as shown in the wiring diagram. The diagram shows connections for a ring main circuit. Figure — 7
5. For radial circuits or a spur off a ring main there will only be one cable.

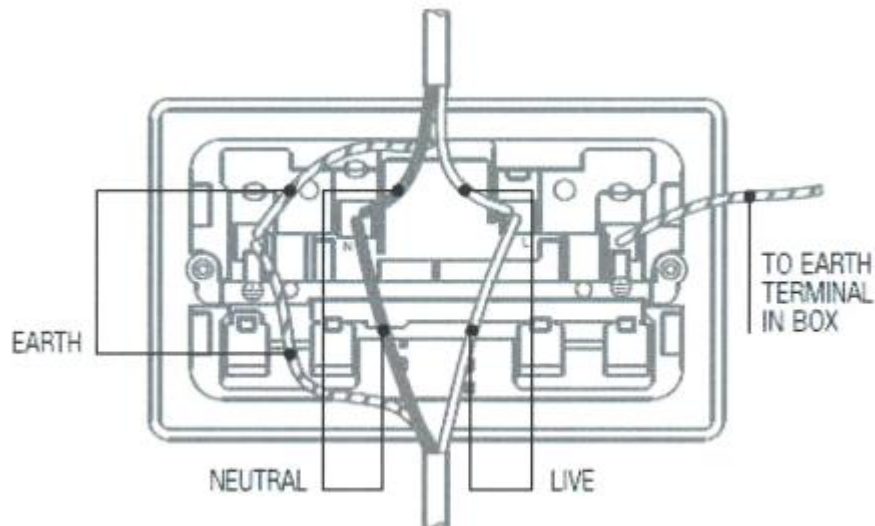

**Sample Figure — 7 (Double Switch Socket Outlet Connections)**

#### Note:

- a) All types (Normal or IP rated) of switch socket shall be wired according two above details.
- b) Before installing the devices, the data sheet provided by the manufacturer.

##### ii. Installation of Flex Outlet Plate

Document No.	Revision	Title
M002-RLR-ELE-MES-00010	1	MS for Installation of Wiring Devices & Accessories

Flex outlet shall be used according to rating of the device to be connected as per approved shop drawing.

1. The product must be earthed. Connect the cables as shown in the wiring diagram.
2. If required carefully remove the cable cut-out, on the side of the front plate so that the load cable fits neatly within it.
3. Ensure that all sharp edges are removed!
4. Before fitting front plate, ensure that the load cable is securely retained by the cable clamp. Check that the load cable is connected to the appliance. Figure — 8.

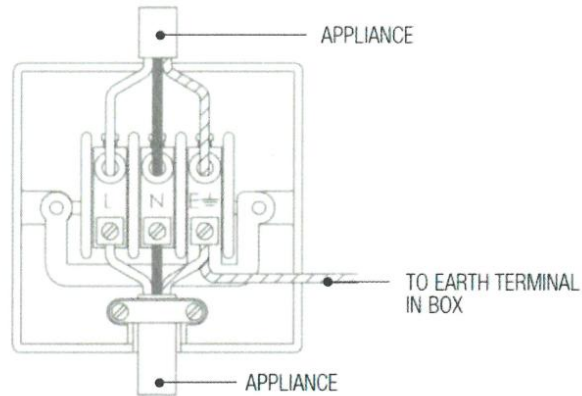

**Sample Figure — 8 (Flex Outlet Connections)**

**Note:** ALL EARTH CONDUCTORS MUST BE IN GREEN/YELLOW COLOUR.

**iii. Installation of Un-Switched Fused Connection Unit**

1. Connect the cables as shown in the wiring diagram Figure — 9. Fitted with a 13 Amp fuse.
2. Ensure that the load cable is connected to the appliance.
3. When used on a ring main there will be two supply cables. Connect both of the cables to the same terminals.
4. For FCU's with flex outlets, pass load cable through outlet before connecting to switch. Ensure cable clamp is fitted and tightened across outer sheath of cable.

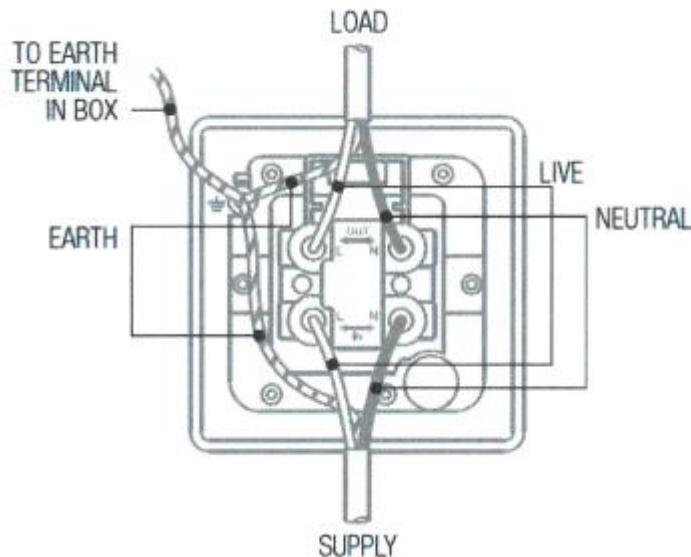

Document No.	Revision	Title
M002-RLR-ELE-MES-00010	1	MS for Installation of Wiring Devices & Accessories

### Sample Figure — 9 (Un-Switched Fused Connections)

#### iv. Installation of Switched Fused Connection Unit

1. Connect the cables as shown in the wiring diagram Figure — 10, Fitted with a 13 Amp fuse.
2. Ensure that the load cable is connected to the appliance.
3. When used on a ring main there will be two supply cables. Connect both of the cables to the same terminals.
4. For FCU's with flex outlets, pass load cable through outlet before connecting to switch. Ensure cable clamp is fitted and tightened across outer sheath of cable.

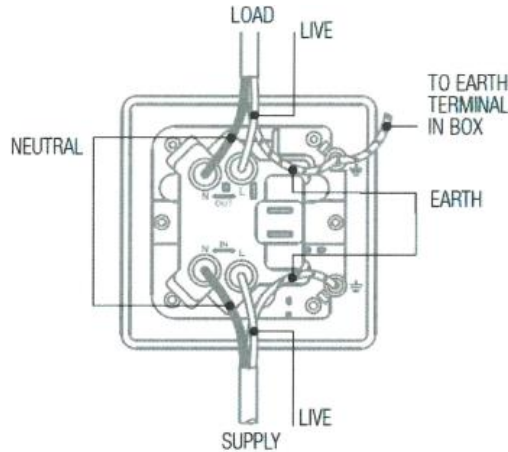

Sample Figure - 10 (Switched Fused Connections)

#### v. Installation of 45 AMP (1 or 2) Gang Switches

1. The product must be earthed.
2. Connect the cables as shown in the wiring diagram. Figure — 11
3. Ensure that the load cable is connected to the appliance.
4. Do not connect this switch directly to ring circuit.

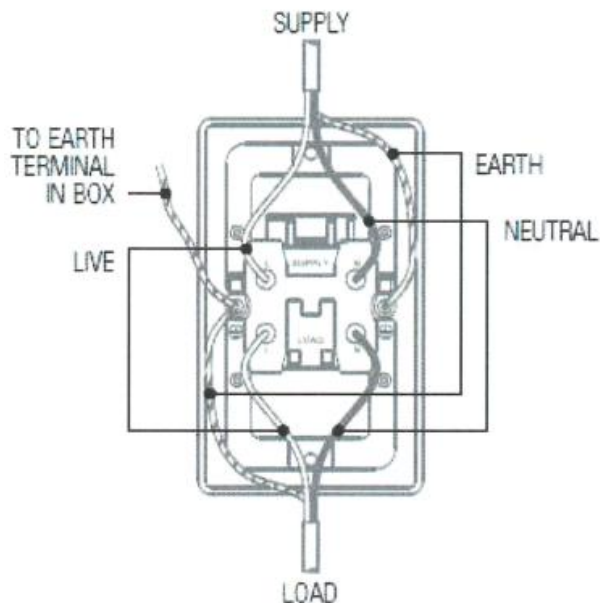

Sample Figure — 11 (45 Amp Switch Connections)

#### vi. Installation of Double Pole Switch Socket

1. Connect the cables as shown in the wiring diagram. Figure — 12 (a & b)

Document No.	Revision	Title
M002-RLR-ELE-MES-00010	1	MS for Installation of Wiring Devices & Accessories

- The diagram shows connections for a ring main circuit. For radial circuits or a spur off a ring main there will only be one cable.

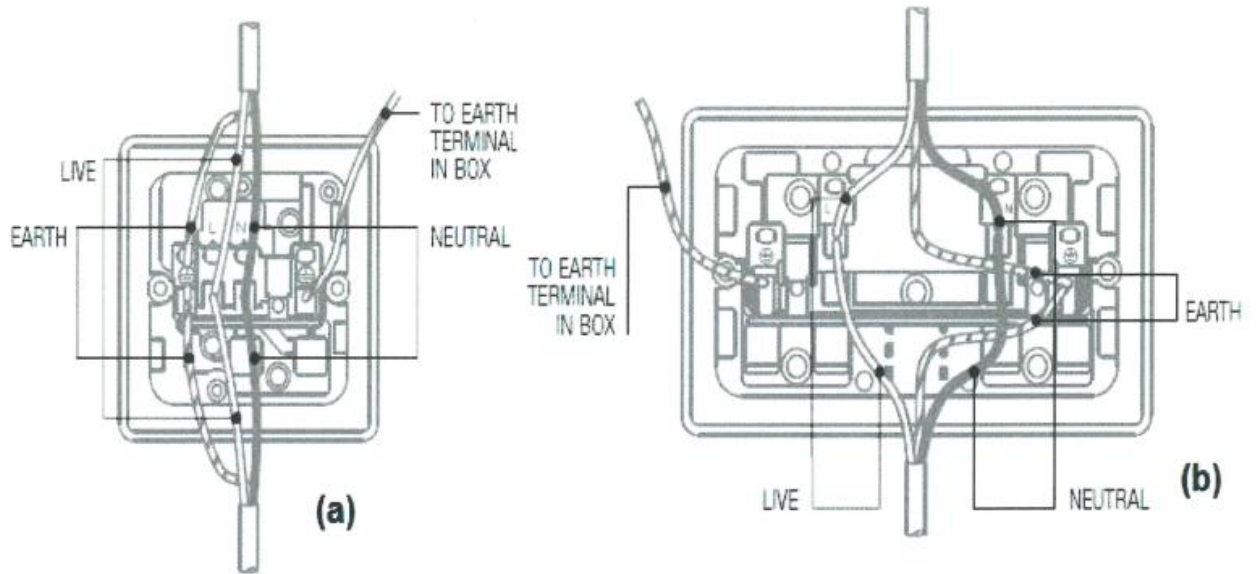

**Sample Figure — 12 (Double Pole Switch Sockets Connections)**

**vii. Installation of Double Pole Switches**

- Connect the cables as shown in the wiring diagram. Figure —13
- Ensure that the load cable is connected to the appliance when used on a ring main there will be two supply cables. Connect both of the cables to the same terminals.
- For switches with flex outlets, pass load cable through outlet before connecting to switch. Ensure cable clamp is fitted and tightened across outer sheath of cable.

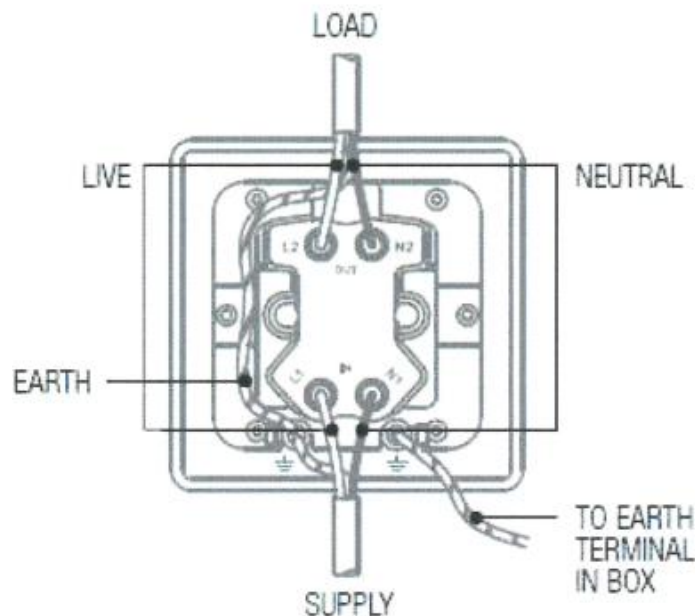

**Sample Figure —13 (Double Pole Switches Connections)**

**viii. Installation of Triple Pole Dis-Connector Switches**

- For use with extractor fans fitted with or without timer control. Provides local isolation for maintenance or repair without the need to isolate the complete circuit.
- Connect the cable conductors as shown in the wiring diagram, ensuring that the correct polarity is maintained between the load and supply conductors.

Document No.	Revision	Title
M002-RLR-ELE-MES-00010	1	MS for Installation of Wiring Devices & Accessories

3. For extractor fans without timers, there will only be two load and two supply conductors.

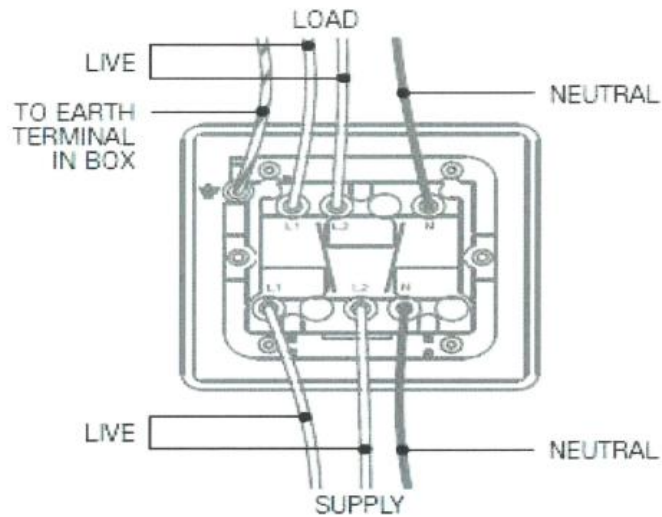

**Sample Figure — 14 (Triple Pole Switches Connections)**

#### 4.2.10 Installation of Lighting Switches

##### i. **GANG 1 WAY SWITCH (1 WAY SWITCHING)**

- Connect the cables as shown in the wiring diagram.

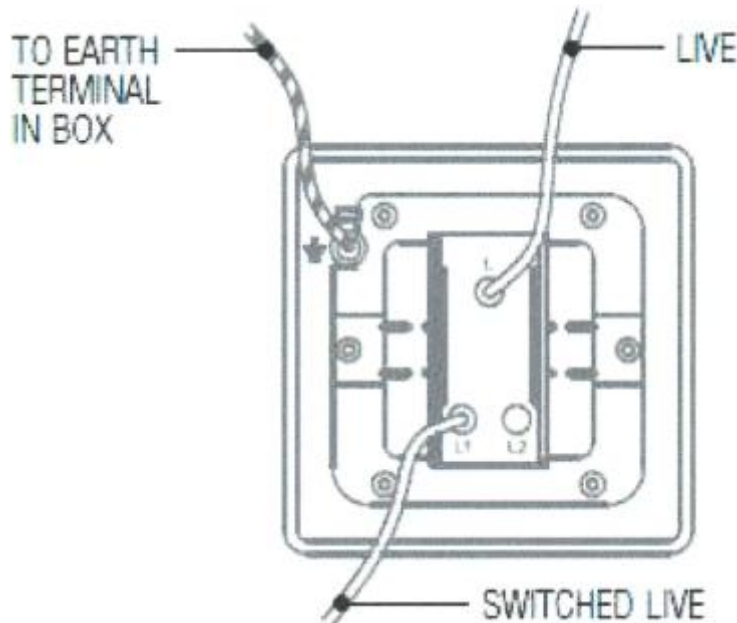

**Sample Figure — 15 (One way Lighting Switch Connections)**

##### ii. **GANG 2 WAY SWITCH (2 WAY SWITCHING)**

- Connect the cables as shown in the wiring diagram.

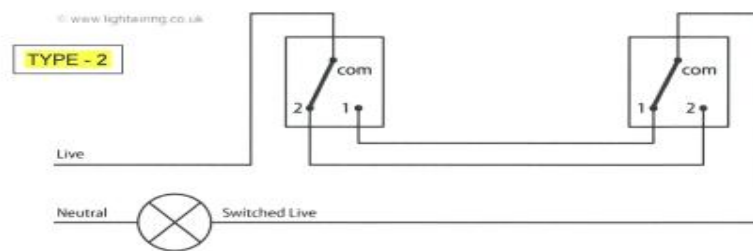
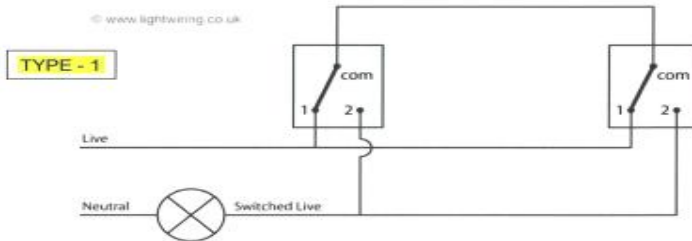
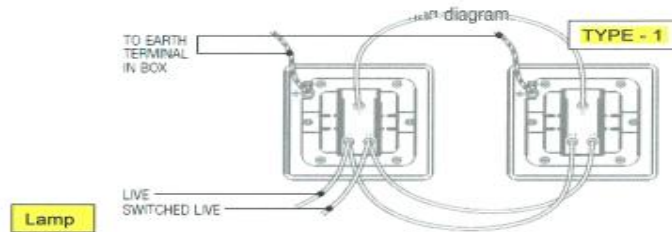

**Sample Figure — 16 (Two-way Lighting Switch Connections)**

**iii. GANG 2 WAY SWITCH (2 WAY SWITCHING)**

-Connect the cables as shown in the wiring diagram Figure - 17.

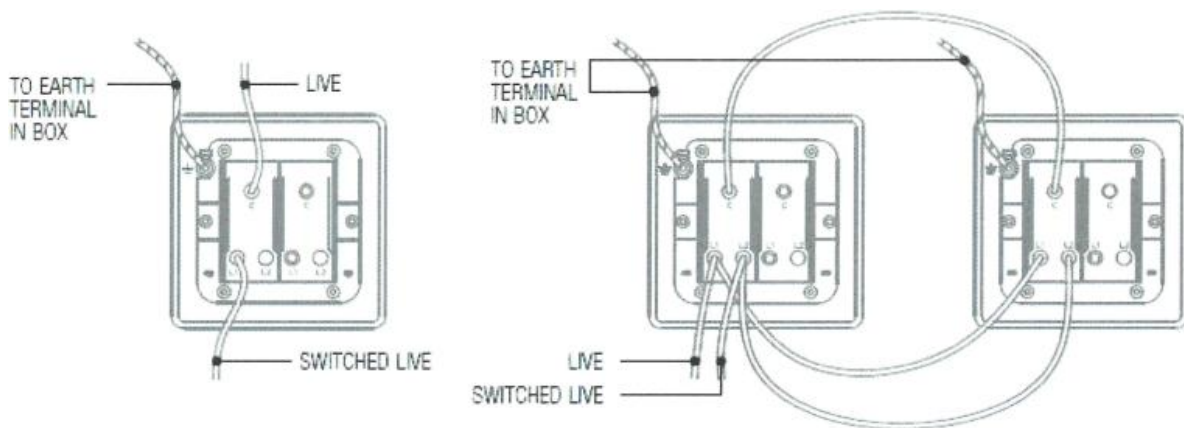

**Sample Figure — 17 (2 Gang Two Way Lighting Switch Connections)**

**iv. GANG INTERMEDIATE SWITCH**

1. Intermediate switches are used if more than two switches are required to control a two-way lighting circuit.
2. It should be fitted between the first and last switches on the circuit.
3. The wiring arrangement, which may be used, is shown in the Figure - 18.
4. If replacing an existing switch, note the location of the terminals and the color and position of cable connections.
5. Ensure that all cables are connected to the corresponding terminals on the new switch.

Document No.	Revision	Title
M002-RLR-ELE-MES-00010	1	MS for Installation of Wiring Devices & Accessories

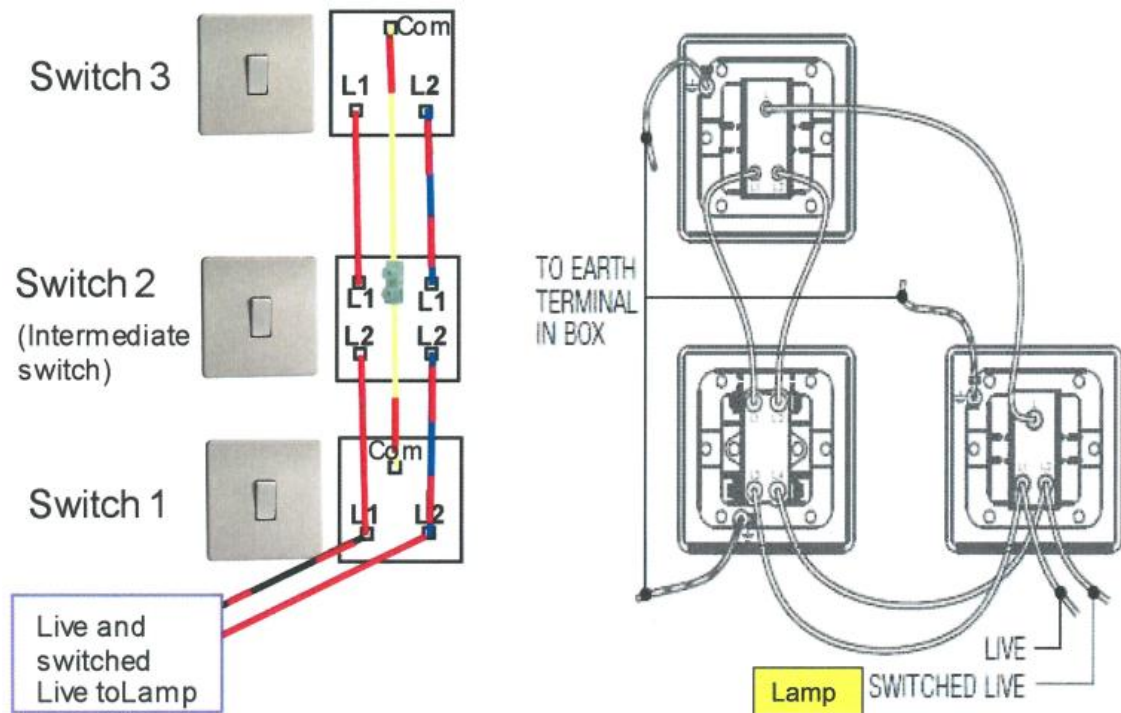

**Sample Figure — 18 (Intermediate Lighting Switch Connections)**

#### 4.2.11 Installation of Ceiling Rose (Plug Type)

The Clip Connector System simply brings plug-in convenience and versatility for lighting. It is a unique modular plug and socket interface that provides simultaneous mechanical and electrical connection in one click-in action.

1. Luminaires shall be plugged in, in seconds, in absolute safety, without circuit isolation.
2. Strong load grips provide support for luminaires, so all types and sizes of luminaires can be safely used.
3. The electrical connection shall be made by latch contacts perpendicular to the natural load direction, thus eliminating strain on the contacts.
4. It reduces time on-site installation.
5. All leads have crimped ends to eliminate breakage, and minimize on-site cable preparation Heat resisting PVC flexible cord.

#### The Preparation Steps for the Plug Ceiling Rose

**Step 1:** Turn the cover anti — clockwise to remove.



**Step 2:** Remove the plug-in termination point by rotating to the left and lifting out.



**Step 3:** The incoming cables from the conduit junction box should be connected to socket according to its markings - please refer to wiring diagram below (End of this table).

**Step 4:** Fix the socket plate back onto the ceiling box ensuring no wires are trapped using the screws provided.



**Step 5:** Connect the light fitting to the plug using suitable cable (flexible should of 2 meters in length minimum) and refer to the appropriate markings -see plug diagram below



**Step 6:** Plug the termination point into the conduit socket cover plate (noting the keyway position) and rotate clockwise until it locks, refit the mains cover by turning clockwise.

**Step 7: Restore power.**

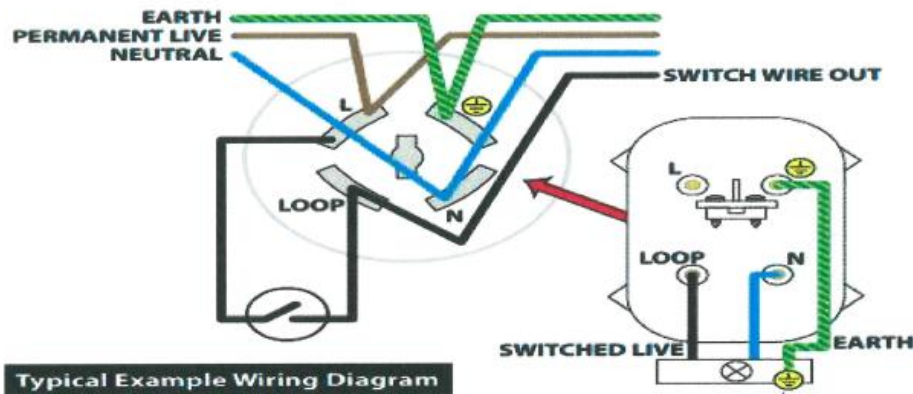

### Special Termination Requirements for Emergency Light fittings

1. For a Central Battery System (CBS) terminate any emergency supply directly into the luminaire without the use of ceiling roses using the specified cable type for the central system throughout the installation.
2. For more Details about the Connection shall be given in Method statements for the
  - a. Back of House Lighting- BOH M002-RLR-ELE-MES-00009
  - b. Front of House Lighting- FOH M002-RLR-ELE-MES-00010
3. If further details or information required for the connection termination of CBS battery, it shall be provided through the Work Instruction (WI) or if necessary a separate Method statement for CBS connections and CBS Panel installation shall be given.

#### 4.2.12 Circuit Continuity: Test

A continuity test is done to determine whether a circuit is open or closed.

Document No.	Revision	Title
M002-RLR-ELE-MES-00010	1	MS for Installation of Wiring Devices & Accessories

For example, a wall switch is closed when it is turned to the "on" position and it is open when it is turned off. An open circuit cannot conduct electricity. A closed circuit has continuity.

### Set Up Procedures

1. Turn the dial to Continuity Test mode ( null ). It will likely share a spot on the dial with one or more functions, usually resistance (0).
2. With the test probes separated, the multi-meter's display may show OL and O.
3. If required, press the continuity button.
4. First insert the black test lead into the COM jack.
5. Then insert the red lead into the V n jack. When finished, remove the leads in reverse order: red first, then black.
6. With the circuit de-energized, connect the test leads across the circuit being tested. The position of the test leads is arbitrary (random).
7. Note that the circuit may need to be isolated from components in the circuit.
8. The digital Multimeter (DMM) beeps if a complete path (continuity) is detected. If the circuit is open (the switch is in the OFF position), the DMM will not beep.
9. When finished, turn the Multimeter OFF to preserve battery life.

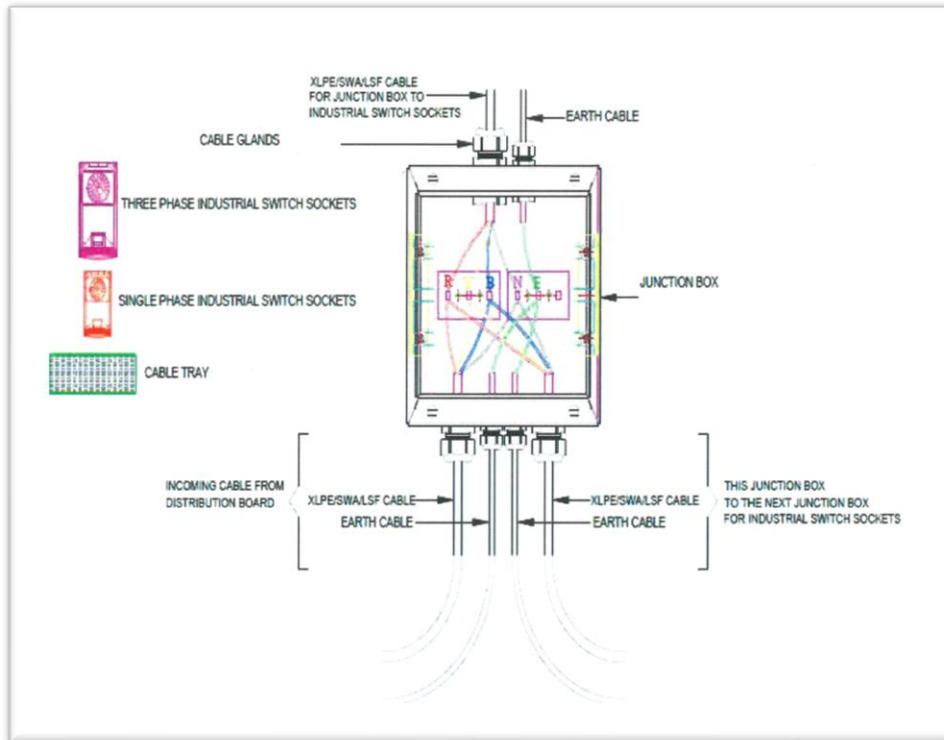

**Figure-19 (Sample Picture) – Multimeter for Continuity Test**

#### 4.2.13 IDENTIFICATION OF ELECTRICAL SERVICES

1. Temporary identification labels and notices shall be provided immediately after installation inspection is APPROVED.
2. Warning, caution and instruction notices where indicated in the engineering system sections of this Specification or on the drawings shall be provided temporarily.
3. It shall be ensured that all identification labels and notices installed in a visible position.
4. Permanent Identification label shall be provided for all wiring devices, power & lighting Circuits and ceiling rose according to the Approved Method statement of "TAG and Marking".( M002-RLR-ELE-MES-00018)

Document No.	Revision	Title
M002-RLR-ELE-MES-00010	1	MS for Installation of Wiring Devices & Accessories



**Sample Figure — 20 (Terminal box Connections details for industrial sockets)**

#### 4.2.14 REDLINE MARK-UP & AS-BUILT

If due to any conditions that arises during the construction phase that construction team is Unable to follow the IFC/Approved drawings. The following procedure shall be followed.

- 1) Mark the new location of wiring devices (Non-Adherence to the approved Shop drawings) then this information shall be detailed in the drawings with Red Lines and shall be part of the documents during the inspection (According to ITP).
- 2) After approval of inspection with changes (RED Lines Drawing). This information will be incorporated in the AS Built drawings.

## 5 Quality

The Inspection and Test Plan (ITP) for this Method Statement summarizes various characteristics to be checked. The concerned Site Engineer or Site Supervisor will be responsible to ensure compliance for these operations and the site QA/QC Engineer will carry out quality control checks and report the inspection results.

### 5.1 Quality Records:

ITP reference No: M002-RLR-ELE-ITP-00010.

Quality records shall be provided as identified in the ITP and maintained as per ISO 9001/QCS 2014 section 2 part 5 QR Quality Guidelines.

Required form of records and reports are defined in the Inspection and Test Plans. Refer to Doc. No: M002-RLR-ELE-ITP-00010.

## 6 Health and Safety Plan:

- a) The Health and Safety Plan: M002-RLR-HMS-PLN-00001 will be strictly adhered to at all times.

Document No.	Revision	Title
M002-RLR-ELE-MES-00010	1	MS for Installation of Wiring Devices & Accessories



## 2. Load shifting Machinery

- i. Do not operate any load shifting machinery without training and approval.
- ii. Operators of forklift trucks, bulldozers, loaders, excavators, trucks should possess appropriate certificates/ Passes.

## 3. Manual Handling

Avoid manual handling operations as far as possible to minimize the risk of injury. Estimate the weight of the load. Lift an object with a correct posture. Wear suitable protective equipment. Put on gloves as far as possible to protect your hands from any cut, scratch or puncture, and wear safety boots or shoes to prevent injury to toes by heavy falling objects .Seek assistance from someone in lifting a load if necessary.

## 4. Portable Power Tool

- i. Do not use a portable power tool (such as saw, grinder and drill) unless its dangerous parts have been effectively guarded.
- ii. Place the electric cable and hose of a tool at an appropriate position to avoid tripping hazards.
- iii. Do not operate a cartridge operated fixing tool unless you have possessed a valid
- iv. certificate.
- v. Wear suitable eye and ear protectors while operating a cartridge-operated fixing tool.
- vi. Use a cartridge-operated fixing tool with great care.

## 5. Scaffold (Mobile)

- i. Do not use scaffolds unless they have been erected by trained workmen and under the supervision of a Supervisor.
- ii. Do not use a scaffold unless it has been inspected and certified safe (A Green Tag to visibly hoist on the scaffolds) by a Certified Supervisor before use.
- iii. Strictly follow the instructions of a Supervisor. Do not alter the scaffold unless authorized to do so.
- iv. Do not work on an unfinished scaffold.
- v. When it is necessary to work on a mobile scaffold, lock the wheels of the scaffold before you start working.
- vi. Do not work on a scaffold unless it has been provided with a suitable working platform.
- vii. Ladders shall be used where no other means of access is possible.

## 6. Safety Requirements.

- i. First Aid Kit to be provided at Station working areas in consultation with HSE officer.
- ii. Clean up work area immediately after each task; never leave an area that is cluttered
- iii. with tools or supplies that could present tripping hazard.
- iv. Barriers as required shall be in place wherever necessary.
- v. Visible "Safety sign" shall be provided where necessary as per HSE requirements.
- vi. Good quality gloves are to be worn to protect your hands when using the equipment or handling materials.
- vii. The basic Personal Protective Equipment for this particular job are:
  - a. Hard Hats (Hat Colours as specified by HSE Department)
  - b. Gloves (Must Be Task Specific)

Document No.	Revision	Title
M002-RLR-ELE-MES-00010	1	MS for Installation of Wiring Devices & Accessories

- c. Goggles (Clear Glass for underground areas and Black Glass for work in Sun Light)
- d. Reflective Vest
- e. Safety Boots (High Ankle as Qatar Rail)

Note: Always wear safety spectacles when using the equipment.

Other specific risks & measures are addressed in the Risk assessment attached in Appendix B.

## **7 Environmental:**

---

The site team including subcontractors shall implement the following environmental controls measures:

- a) The waste material from the installation of Wiring and Accessories are to be placed in waste skips provided at site.
- b) Unused materials shall be returned to the stores for appropriate storage according to manufactures' instructions for potential reuse;
- c) Colour coded skips with signage shall be provided for waste segregation (general waste, metals, and plastics). Separate colour coded storage skips to be used for hazardous material.
- d) Good housekeeping shall be maintained regularly at job site.

## **8 Interfaces and Permits**

---

### 8.1 Interfaces

- Not Applicable

### 8.2 Permits

- Not Applicable

## **9 Appendices / References:**

---

### 9.1 Appendices:

- Appendix A – Inspection and Test plan;
- Appendix B– Risk Assessment;
- Appendix C– Test Report;

### 9.2 References:

This Method Statement shall be read in conjunction with the following documents:

#### **Material Submittal:**

Material submittal for Wiring Devices & Accessories.

Material Submittal for Fir Resistant Multicore Armoured Cables.

Material Submittal for Low Voltage LSOH Cables & Wires.

Material Submittal for Distribution Boards.

Material Submittal for Cable Accessories.

Material Submittal for Light Fixtures & Accessories – Back of House Area.

Material Submittal for Light Fixtures & Accessories – Front of House Area.

Document No.	Revision	Title
M002-RLR-ELE-MES-00010	1	MS for Installation of Wiring Devices & Accessories

**Method Statement For:**

Document No.	Document Title
M002-RLR-ELE-MES-00001	Installation of Cable Containment System
M002-RLR-ELE-MES-00002	Installation of GI Conduits, Flexible Metallic Conduits & Accessories
M002-RLR-ELE-MES-00011	Installation of LV Cables & Wires
M002-RLR-ELE-MES-00008	Installation of Lighting Fixtures & Accessories – Back of Houses
M002-RLR-ELE-MES-00009	Installation of Lighting Fixtures & Accessories – Front of Houses
M002-RLR-ELE-MES-00010	Installation of Distribution Boards & Accessories

**Specifications:**

Document No.	Document Title
M002-RLR-MEP-TEN-00008	Material and Workshop Specifications Volume 7
M002-RLR-MEP-SPE-27005	DD2 –Qatar University Station-WP11.2 MEP Specifications
M002-RLR-MEP-SPE-36303	DD2 –Lusail Station-WP18.2 MEP Specifications
QCS 2014	QCS 2014 Section 21 Part 10
M002-RLR-ELE-SPE-36013	Lusail Station - WP18.2 - DD2 - Earthing and Bonding Specifications
QCDD Qatar Civil Defence Department	Design and construction Regulations and fire Safety Standards
KAHRAMAA	Section 7, (Final Sub Circuits), and Section 8 (Electric Motors, Circuits and Controllers)
Volume 6 –Contract's Requirements Design Speciation's	13.3 Electrical Works Description,(13.3.2 General Design Criteria) 13.3.3 Station
BS EN 7671	Standards for Electrical Installation
NFPA 70	National Electrical Code ®

**Reports & Calculation:**

Document No.	Document Title
M002-RLR-MEP-RPT-27003	
M002-RLR-ELE-RPT-26000	
M002-RLR-ELE-CLN-26004	

Document No.	Revision	Title
M002-RLR-ELE-MES-00010	1	MS for Installation of Wiring Devices & Accessories